

IGRP 100mm BASE DETAIL  
RECOMMENDED

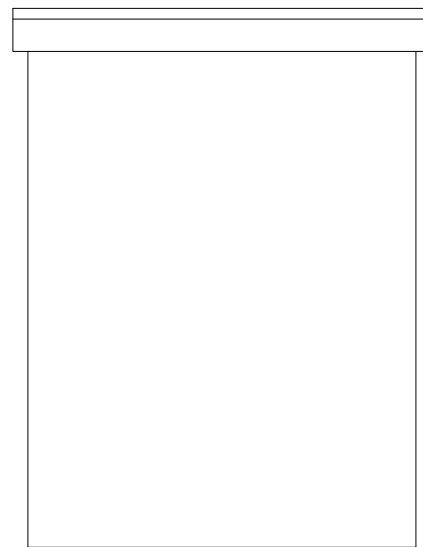

EXTERNAL VIEW ON REAR WALL

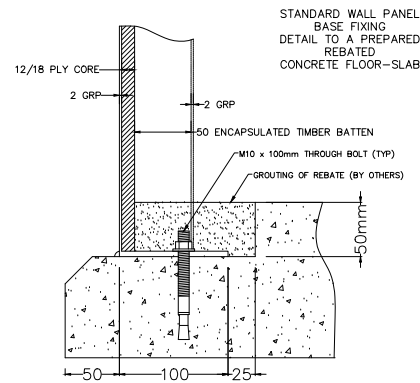
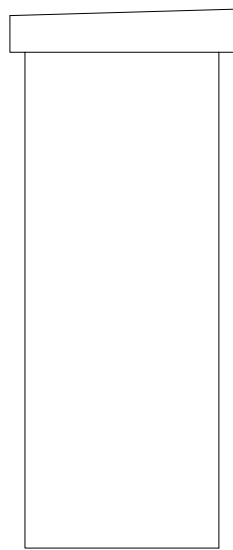
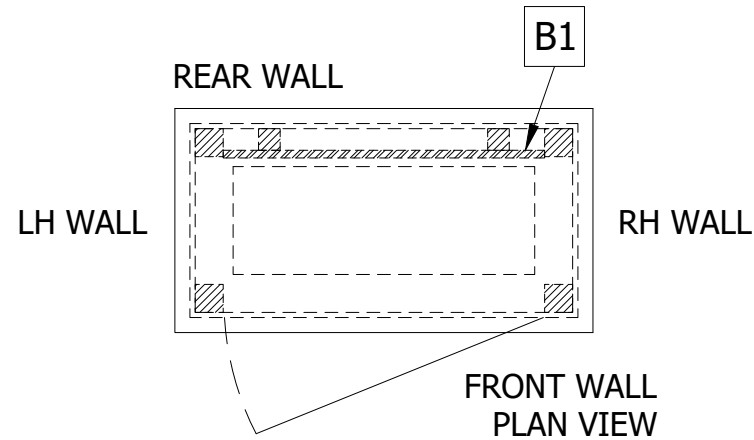

EXTERNAL VIEW ON LH WALL

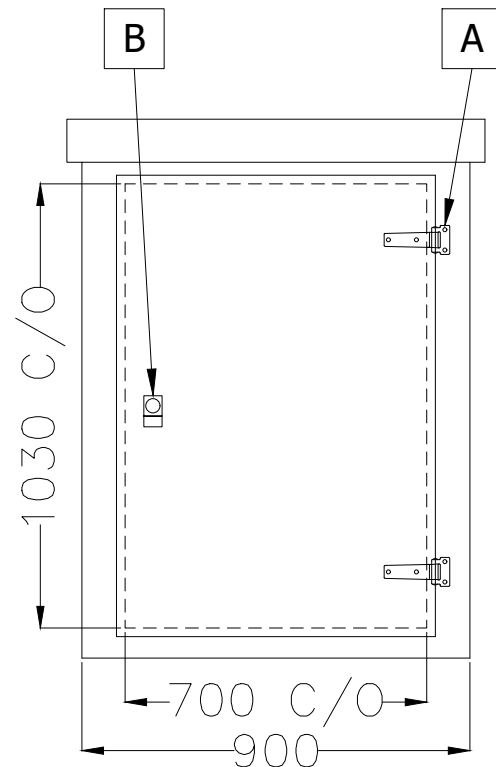

EXTERNAL VIEW ON FRONT WALL

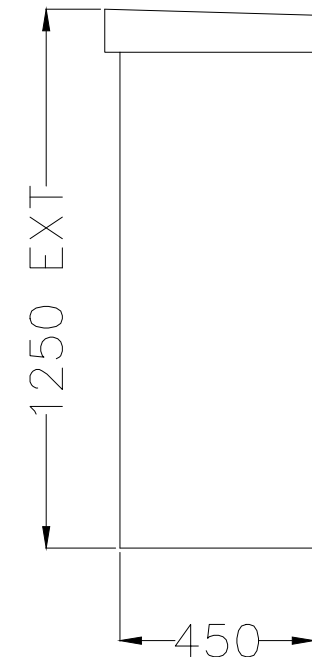

EXTERNAL VIEW ON RH WALL

CONSTRUCTION:	GRP/12mm PLY/GRP
EXTERNAL FINISH:	SMOOTH GEL
EXTERNAL COLOUR REF:	INSERT COLOUR REF
INTERNAL FINISH:	MATT GRP
INTERNAL COLOUR:	WHITE
BASE FLANGE:	100mm
INSTALLATION TYPE:	<b>READY-BUILT</b>

PARTS LIST / LEGEND:		QTY:
A	STAINLESS STEEL HINGES	2
B	CYLINDER LOCK	1
B1	FULL W X FULL H X 18mm TREATED PLY BACKBOARD	1

PRODUCTION NOTES:

ESTIMATED KIOSK WEIGHT:	100Kg
A	
-	FIRST ISSUE 00/00/00
REV:	DETAILS OF REVISION DATE:

THIS DRAWING AND DESIGN IS THE PROPERTY OF INDUSTRIAL GRP AND WITHOUT THE WRITTEN CONSENT OF INDUSTRIAL GRP LTD MAY NOT BE COPIED IN WHOLE OR IN PART OR COMMUNICATED IN ANY FORM TO A THIRD PARTY.

**INDUSTRIAL GRP**  
 HEAD OFFICE TEL: 01269 845 800  
 WEBSITE: WWW.INDUSTRIALGRP.CO.UK  
 BLOCK 2 UNIT C, CAPEL HENDRE INDUSTRIAL ESTATE, AMMANFORD, CARMARTHENSHIRE, SA18 3S3

TITLE:	C2 CABINET
CLIENT:	-----
DRAWING REF:	-----
DATE: 00/00/00	DRAWN BY: -- CHECKED BY: -- REV: -